

Engine

Cummins QSB 6.7, EU Stage IV

Net Power

162 Hp (119 kW)

Operating Weight

22,800 kg

Bucket Capacity

0.9 – 1.2 m³

922E
EXCAVATOR



TOUGH WORLD. TOUGH EQUIPMENT.

A POWERFUL VISION

Today, LiuGong is a leader in China's construction equipment industry and is one of the fastest growing construction equipment companies in the world, providing customers with quality, reliable support across a wide range of equipment.



WHAT MAKES LIUGONG A LEADER?

LiuGong built China's first modern wheel loader and continues to embrace its commitment to innovation by combining decades of know-how with leading technology from the world's best component suppliers.

LiuGong has established centers of excellence around the globe to guarantee service and support and ensure their customers can work efficiently and

productively. LiuGong manufacture at 20 plants and have offices across all major regions of the world including Europe, North America, South America, Asia-Pacific, India, the Middle-East, South Africa and Russia.

An extensive network of regional parts depots operate around the globe to ensure customers receive the support they have come to expect from LiuGong.

Innovation and manufacturing excellence for over 60 years

INNOVATIVE FROM THE START

Innovation drives industries forward and LiuGong has been **driving innovation for over 60 years.**

An 110,000m² Global Research & Development Centre in Liuzhou, China is equipped with world-class technology and run by industry experts including around 1,000 R&D engineers.

In addition to the Liuzhou facility LiuGong operates world-class R&D facilities in Poland, India, the United States and the United Kingdom, supporting their global vision of excellence.

Emphasis on quality is reflected in LiuGong's Six Sigma quality methodology and compliance with ISO 9000 standards.

LiuGong has established joint venture partnerships with some of the industry's best known names including:

- German drivetrain components manufacturer **ZF Friedrichshafen AG**
- Finnish mining and aggregates processing equipment manufacturer **Metso**
- North American diesel engine manufacturer **Cummins**

WE ARE LIUGONG



9,500+
Employees



20
Factories



13
Regional subsidiaries



300+
Dealers



1,000+
R&D engineers



5
R&D facilities



12
Regional
parts depots



Over 60
Years' experience



LOAD UP ON EFFICIENCY

LiuGong E series excavators deliver the **perfect balance** of efficiency, versatility and precise control. Powered by the latest generation, low emission Cummins QSB 6.7 engine, the 922E model features **enhanced power output**, faster cycle times and improved breakout force.

FUELWISE 6 CYLINDER ENGINE

The 922E's 162 hp (119 kW) Cummins engine meets strict EU Stage IV emissions standards, delivering heavy-duty power without compromising on fuel economy.

The field proven QSB 6.7 engine features a cooled-EGR system and the latest AdBlue technology, complemented by Cummins' patented VGT™ Turbocharger which precisely adjusts the airflow delivered to the engine, increasing performance and ensuring excellent fuel efficiency.

ADVANCED HYDRAULICS

Within the advanced hydraulic system of LiuGong excavators, negative flow of the hydraulics optimizes the main control valve and helps to maximize the cycle time of the cylinders. This leads to improved efficiency and a higher rate of work completed. The hydraulic system is highly proficient in transferring engine power to the ground while providing precise control.

INTELLIGENT POWER CONTROL

LiuGong's advanced Intelligent Power Control (IPC) system delivers the power you need, when you need it, ensuring powerful performance without fuel wastage. The new-generation computer-aided IPC system utilizes the mechanical, electrical and hydraulic systems of the 922E to work in perfect harmony for quality, precise control. When the working load increases, engine power and hydraulic pump flow respond to meet the exacting demands of the job.

WORK YOUR WAY

LiuGong's six selectable work modes give you full control of the machine and enhanced performance under various operating conditions:



Power



Economy



Fine



Lifting



Breaker



Attachment

ALWAYS EFFICIENT

The 922E's automatic warm-up system brings the engine up to operating temperature swiftly, enhancing fuel consumption, reducing emissions and maximizing uptime.

The 922E further increases fuel economy by regulating its idle speed. If there is no hydraulic request signal detected from

the joystick, even for just one second, the engine speed is automatically dropped by 100 RPM. If no activity is detected over three seconds the engine speed will decrease to idle. As soon as the system detects the hydraulic signal once more, the engine will immediately return to the previous throttle speed setting.

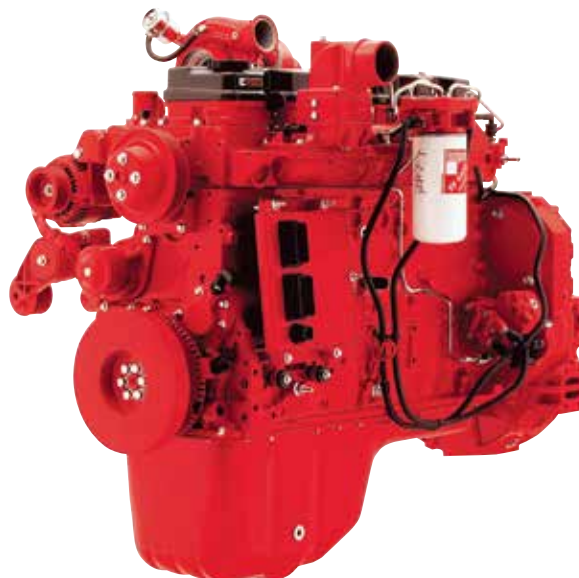

READY FOR PEAK PERFORMANCE

The 922E is designed to get a lot of work done in a short amount of time. Featuring a **stronger boom arm** and bucket breakout force, greater hydraulic flow, higher swing speeds and improved cycle times, this excavator will **make light work** of powering through any task in any terrain.

PROVEN PERFORMANCE

The Cummins QSB 6.7 engine produces net power of 162 hp (119 kW) and torque of 809 Nm. LiuGong makes it easy for even the most inexperienced of operators to be productive by harnessing this power across the six working modes of the 922E excavator. Just select the mode that matches the work type and the job can be completed in quick time.

SMART HYDRAULICS

Load-sensing hydraulics direct the engine's power to ensure hydraulic pump flow continually adjusts for smooth, quick and efficient operation. It's where intelligence meets brute force. Engine power and hydraulic pump flow are automatically reset to adjust for the load attachment, helping to optimize the productivity of the machine.



RUGGED MACHINE DESIGN

The 922E's tough and reliable frame provides increased strength, reduced wear, and improved transmission of power to the ground.

ALWAYS VERSATILE

LiuGong's quick coupler and PowerLatch tilt coupler maximize your uptime by making changeover of attachments like buckets, breakers and shears, quick and simple.

TAKE CONTROL

Ergonomically designed controls, clear and informative displays, enhanced visibility, and outstanding comfort increases operator efficiency and safety. Add to that the easily accessed service points for critical daily servicing and routine maintenance and this machine is sure to be well looked after.







TOUGH & DURABLE STRUCTURES

The use of thick, high-tensile steel components, internal baffling and stress-relieved plates, make the structures on LiuGong E-series excavators **strong and reliable**.

We guarantee the **quality and reliability** of our machines throughout the manufacturing process by conducting rigorous tests and ultrasound inspections that identify defects well before they make it into production.

BOOM & ARM

Large cross-sectional supports incorporating one-piece steel castings are designed into the boom and arm structures. This solid engineering guarantees long-term durability and high resistance to torsional stresses. Standard rock-guard plates and vertical guards protect the arm in rocky digging conditions and tough work environments.

UPPER STRUCTURE

The upper structure is strongly reinforced by the use of an H-beam in the high cross section of the main structure providing even weight distribution and increased stability.

The platform's collision protection system has been welded into place to improve its strength, rigidity and overall service life.

UNDERCARRIAGE

The high-strength undercarriage of the 922E incorporates a welded X-frame construction for longevity and is designed to perform in the most challenging conditions. A long track beam and crawler

system provides increased stability when using attachments for digging and truck loading. The result is superior strength and durability all around.



HARD WORK MADE EASY

We understand how operators like to work and have designed the 922E cab to ensure **maximum operator comfort**, enhanced productivity and excellent visibility all-round.



AT HOME IN THE CAB

The 922E's large and spacious cab has all the key features to make excavator operation as safe and comfortable as possible while boosting operator efficiency shift after shift.

The E-series cab is designed to reduce noise and vibration, putting operators comfort first. Convenient additions include cup holders, an AM/FM radio and MP3 player, refrigerated storage and personal luggage compartment. The cab is also fitted with a roof skylight that can be opened or closed as the operator chooses.

ADVANCED CLIMATE CONTROL

An advanced climate control system creates the right environment in any weather, all year round, while dust is eliminated thanks to the complete sealing of the pressurized cab.

COMMAND & CONTROL

LiuGong has carefully designed the cab controls to be perfectly positioned, right where you need them. All hand and foot controls are precisely placed to allow for ease of access and operation. In addition, the multi-adjustable, air-suspension seat has an option for electric heating.



LARGE LCD MONITOR

The easy-to-read, full-color LCD monitor displays all the critical information you need about the machine, including working mode, hydraulic oil temperature, hydraulic pressure and service intervals.

ALL ROUND VISIBILITY

The cab features a large glass surface for exceptional jobsite visibility. With the addition of an optional rear-view camera, the operator can safely see all around the 922E.



EASY SERVICE COMES STANDARD

LiuGong excavators have been **specifically designed** for easy service and maintenance in even the most remote and harsh environments.

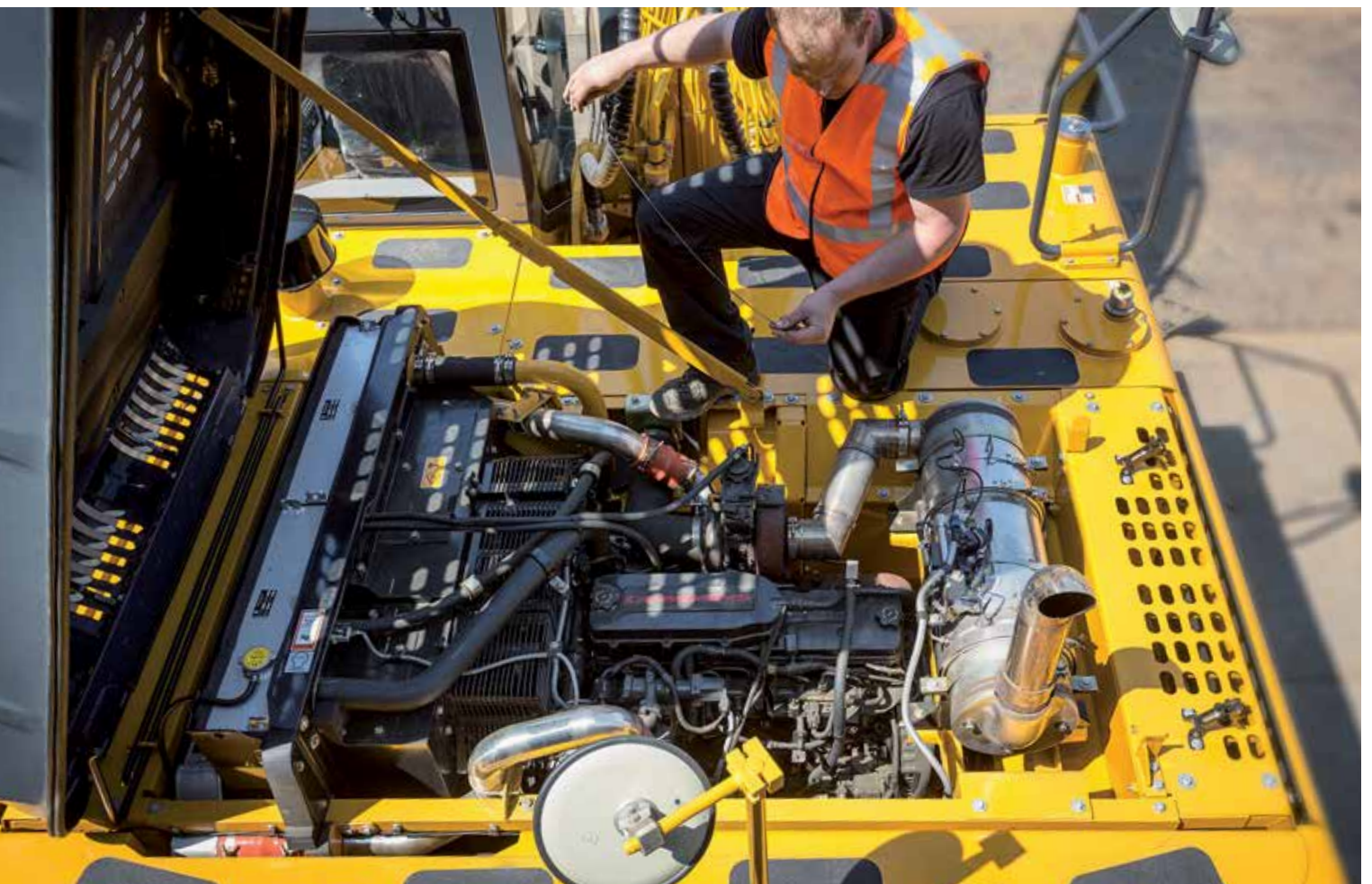

MAXIMIZE YOUR UPTIME

If servicing is easy, it gets done. An automatic greasing system makes daily maintenance simple and quick, helping to lower maintenance costs and improve machine productivity. The automatic system improves bearing life and reduces repairs by delivering regular and precise amounts of grease to each bearing. Optimal design and layout of all other maintenance features makes it easy for the operator to complete essential servicing tasks.

The 922E is designed with easily accessible service points:

- Easily visible hydraulic oil level gauge
- Accessible, grouped filters
- Easy to replace A/C filter next to the cab door
- Maintenance free air filter

ON BOARD MONITORING

Using the LCD display, the operator can easily check oil temperatures and pressure levels, receive service interval alerts and access other information that contributes to simple maintenance and servicing of the machine.

PART OF YOUR PERFORMANCE



We know that confidence in your machine and those who support it is essential. So at LiuGong, we make sure we can always get what you need without delay, via our nine global parts depots, and the support of our network of local dealers across 130 countries worldwide.

LiuGong engineering sets high standards and all parts are rigorously tested to ensure they can meet the rigid quality specifications required for long lasting performance. No matter where you are in the world, we can ensure fast and efficient parts support to keep you going.

READY FOR ANY JOB

To ensure increased versatility on any jobsite, LiuGong provides a range of purpose designed attachments, hitches and tools for your 922E. In-cab dial-in hydraulic flow settings through the display screen optimizes the performance of your attachment.



BUCKETS



QUICK COUPLER



TILT COUPLER



BREAKER



SHEAR

MAXIMUM RETURN ON YOUR INVESTMENT

LiuGong's **customer-driven** design and **quality-focused** engineering creates lasting value that will deliver to your bottom line.

PROVEN POWER

Unmatched performance driven by the Cummins QSB 6.7, EU Stage IV Engine, enhances torque output with more power and breakout force at lower engine speeds.

IPC (INTELLIGENT POWER CONTROL)

This system ensures the mechanical, electrical and hydraulic systems work in perfect harmony for efficient, precise control.

AUTO-IDLE SPEED FUNCTION

Hydraulic request signals detect activity, decreasing and increasing engine speed as required. Power is supplied only as needed, achieving optimum fuel efficiency.

VERSATILITY

Options for auxiliary hydraulic piping include bidirectional variable high flow line, an additional line for rotating attachments and also a single acting line. The quick coupler further ensures you get the most out of your machine by easily switching between a wide range of attachments to suit any application.



BOOM AND ARM

Boom and arm structures are designed for long-term durability and resistance to bending and torsional stress. Large cross-sectional areas incorporate one-piece steel castings to provide improved strength and standard rock guard plates and vertical guards further protect the arm in rocky conditions.

UNDERCARRIAGE

Outstanding stability and durability come from an X-type reinforced frame and the long track beam and crawler system.

REAR VIEW CAMERA

Like an extra eye outside the machine, the optional rear view camera sends images to the in-cab colour LCD monitor, creating a safer working environment as you concentrate on the work at hand.

PARTS

Using genuine LiuGong parts is key to keeping your costs low and your machine in top working order. Our extensive support network is always there when you need it, to maximize your business profitability.

AFTER SALES SERVICE

With over 300 dealers, you can feel confident that LiuGong dealers and regional offices will be there to support you with training, service and maintenance and expert advice for the life of your machine.





WHERE YOU NEED US WHEN YOU NEED US

We are there, where you need us, when you need us. LiuGong is **committed** to providing you with **tough equipment** backed by dependable support you can count on.

GLOBAL NETWORK

LiuGong offers local support through an extensive dealer network in more than 100 countries. Our dealers and customers are supported by 13 regional subsidiaries and 12 regional parts depots, all offering expert training, parts and service support.

PROFESSIONAL ADVICE

We are committed to reducing your total cost of ownership and increasing your profits. As part of this, LiuGong's experts will provide targeted advice on everything from choosing the right machine for your needs to maximizing its efficiency on site.

AFTERSALES EXPERIENCE

LiuGong supports you long after your purchase. With over 300 dealers, you can be confident we have the backup you need to maximize your machine's uptime whilst keeping your running costs down. A worldwide parts network will help make maintenance easy and parts available where and when you need them.

SERVICE AGREEMENTS

Take control of your costs by utilizing LiuGong's customer-focused service agreements. Talk to us today.



We are committed to reducing your total cost of ownership and increasing your profits.

SAFETY BUILT IN

LiuGong's commitment to you includes an equal commitment to your **safety**. E-series excavators are equipped with all the necessary safety features to give you peace of mind and help you **focus** on the job at hand.

SAFETY STANDARDS

LiuGong excavators are certified to European CE standards and meet ISO safety standards.

ENHANCED VISIBILITY

The large glass surface area of the E-series cab, combined with the optional rear view camera, provides an extraordinary view of the 922E's surroundings. This ensures the operator is always aware of the immediate environment, while adding LED work lights provides clearer vision on jobsites.

ROLL OVER PROTECTION SYSTEM

The cab's high-strength ROPS ensures operator protection in a worst-case scenario.

FALLING OBJECT PROTECTION SYSTEM

In the extreme environments the 922E is designed to work in, the choice of Falling Object Protection (FOPS) is an invaluable addition to operator safety.

SAFE ENTRY

Safety rails and well-positioned anti-slip tape on the upper part of the machine make it easier and safer during machine servicing.





SPECIFICATIONS

ENGINE

Description

6.7 liter, 6-cylinder straight turbocharged diesel engine

Emission rating		EU Stage IV
Engine manufacturer		Cummins
Engine model		QSB 6.7
Aspiration		Variable-Geometry Turbocharger (VGT)
Charged air cooling		Aftercooler
Cooling fan drive		Viscous clutch
Displacement	L [Inches ³]	6.7 [409]
Rated speed		2100 rpm
Engine output - net	hp [kW]	162 [119]
Engine output - gross	hp [kW]	175 [129]
Maximum torque		809 Nm @1500 rpm
Bore × Stroke	mm	107 × 124

UNDERCARRIAGE

Track shoe each side		49
Link pitch	mm	190
Shoe width, triple grouser	mm	600/700/800/900
Bottom rollers each side		8
Top rollers each side		2

SWING SYSTEM

Description

The high-torque piston swing motor, with integral spring set, and automatic hydraulic release swing brake, is bolted directly to the swing reduction planetary swing gear box. The swing brake automatically resets for safer operation within five seconds of the swing function lever being brought to neutral. This ensures safe travel and parking conditions.

Swing speed		11.4 rpm
Swing torque		78200 Nm

HYDRAULIC SYSTEM

Main pump

Type		Two variable displacement piston pumps
Maximum flow	L/min	2 × 224

Pilot pump

Type		Gear pump
Maximum flow	L/min	19

Relief valve setting

Implement	MPa	34.3/37.3
Travel circuit	MPa	34.3
Slew circuit	L/min	25.5
Pilot circuit	L/min	19

Hydraulic cylinders

Boom Cylinder – Bore × Stroke	mm	120 × 1335
Stick Cylinder – Bore × Stroke	mm	135 × 1490
Bucket Cylinder – Bore × Stroke	mm	115 × 1120

DRIVE AND BRAKES

Description

The tracks are driven by a one-piece two-gear piston hydraulic motor with reducer. The motor and hydraulic pipelines are hidden in the track mechanism to prevent damage from rugged surfaces. The parking brake and shock-absorbing valves are installed inside the motor, ensuring stable travel and parking as well as reliable braking.

Max. travel speed	High: 5.6 km/h
	Low: 3.3 km/h
Gradeability	35° / 70%
Max. drawbar pull	220 kN

SERVICE CAPACITIES

Fuel tank	420 L
Engine oil	25 L
Final drive (each)	5.5 L
Swing drive	3.4 L
Cooling system	25 L
Hydraulic reservoir	210 L
Hydraulic system total	330 L
DEF tank	35 L

ELECTRIC SYSTEM

System voltage	24 V
Batteries	2 x 12 V
Alternator	24V - 70A
Starter motor	24V - 7.8kW

SOUND PERFORMANCE

Interior sound level (ISO 6396)	69 dB(A)
Exterior sound level (ISO 6395)	100 dB(A)

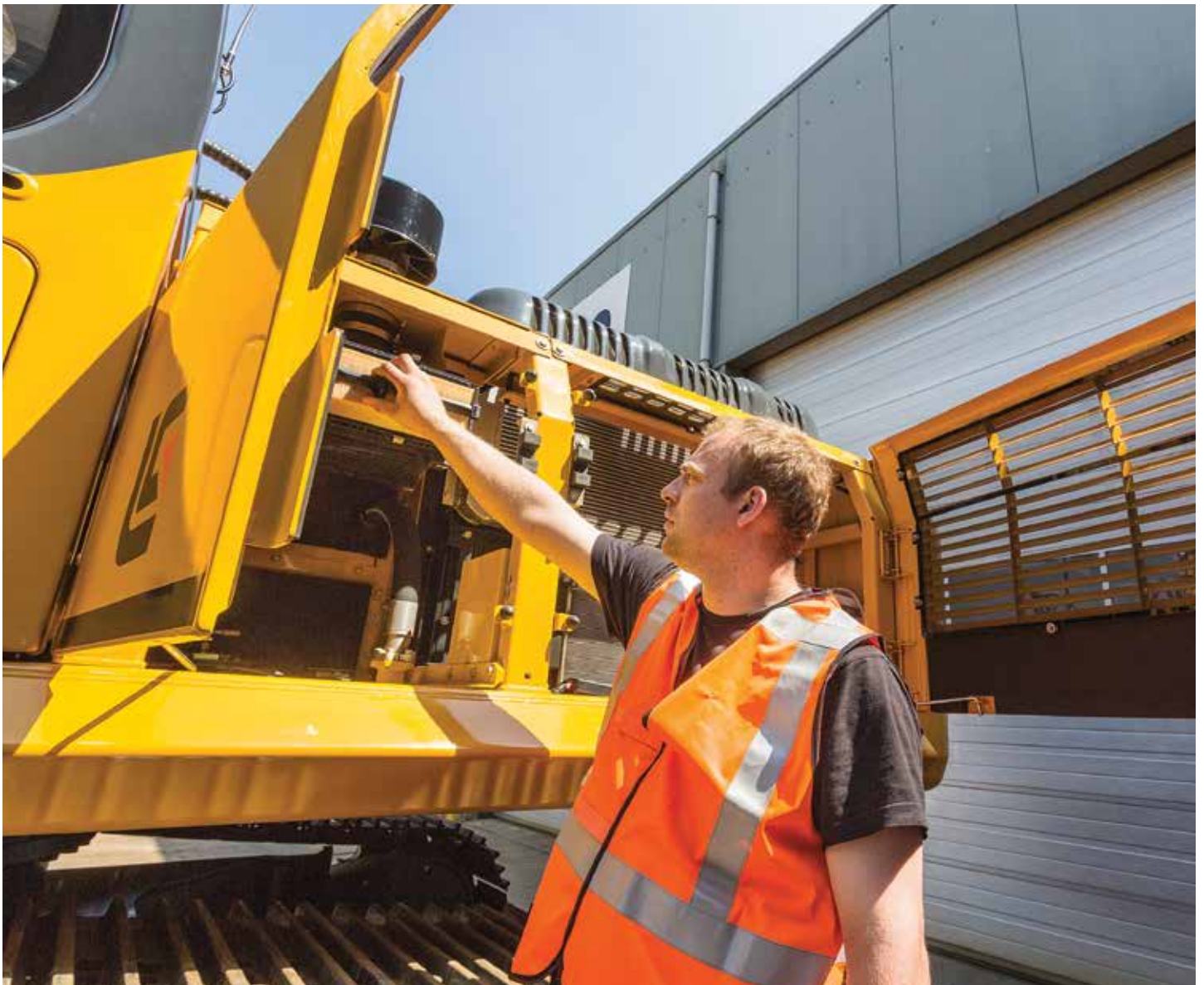

SPECIFICATIONS

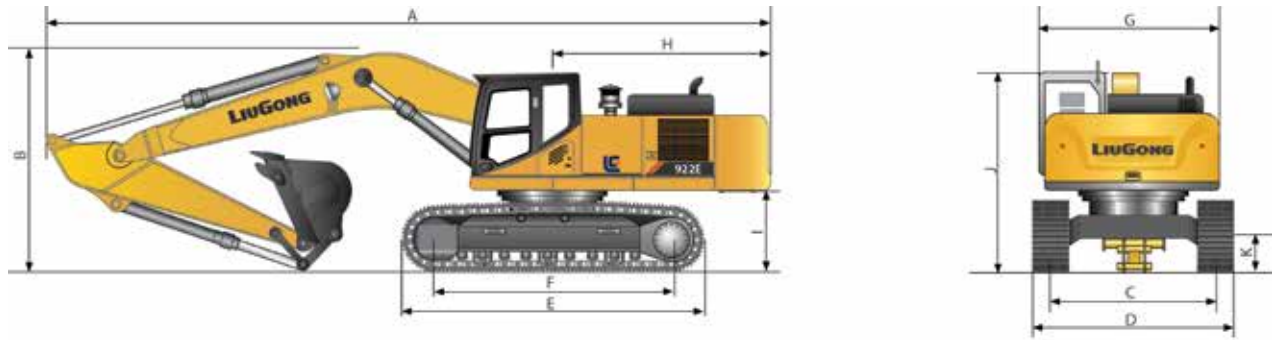

DIMENSIONS			
	UNIT	922E	
Boom options	m	5.7 m	
Arm options	m	2.9	2.7
A Shipping length	mm	9570	9565
B Shipping height – top of boom	mm	3140	3140
C Track gauge	mm	2390	2390
D Undercarriage width	mm	2990	2990
700mm shoes	mm	3090	3090
800mm shoes	mm	3190	3190
900mm shoes	mm	3290	3290
E Track length	mm	4440	4440
F Length to center of rollers	mm	3650	3650
G Overall width of upper structure	mm	2760	2760
H Tail swing radius	mm	2780	2780
I Counterweight ground clearance	mm	1070	1070
J Overall height of cab	mm	3040	3040
K Min. ground clearance	mm	440	440
L Track shoe width	mm	600	600

BOOM DIMENSIONS			
	UNIT	mono	
Boom	m	5.7 m	
Length	mm	5915	
Height	mm	1550	
Width	mm	621	
Weight	kg	1895	

Includes cylinder, piping and pin, excludes boom cylinder pin.

ARM DIMENSIONS			
	UNIT		
Arm	m	2.9	2.7
Length	mm	3895	3685
Height	mm	790	810
Width	mm	466	466
Weight	kg	1110	1073

Includes cylinder, linkage and pin.



WORKING RANGES

		UNIT	922E	
Boom options		m	5.7 m mono	
Arm options		m	2.9	2.7
A	Max. digging reach	mm	9870	9735
B	Max. digging reach on ground	mm	9685	9550
C	Max. digging depth	mm	6562	6380
D	Max. digging depth (2.44 m level)	mm	6390	6140
E	Max. vertical wall digging depth	mm	5080	5040
F	Max. cutting height	mm	9945	9970
G	Max. dumping height	mm	7170	7200
H	Min. front swing radius	mm	3090	3120
Bucket digging force (ISO)	Normal	KN	140	140
	Power boost	KN	152	152
Stick digging force (ISO)	Normal	KN	97	102
	Power boost	KN	105	111
Bucket capacity		m ³	1.0	1.0
Bucket tip radius		mm	1450	1450

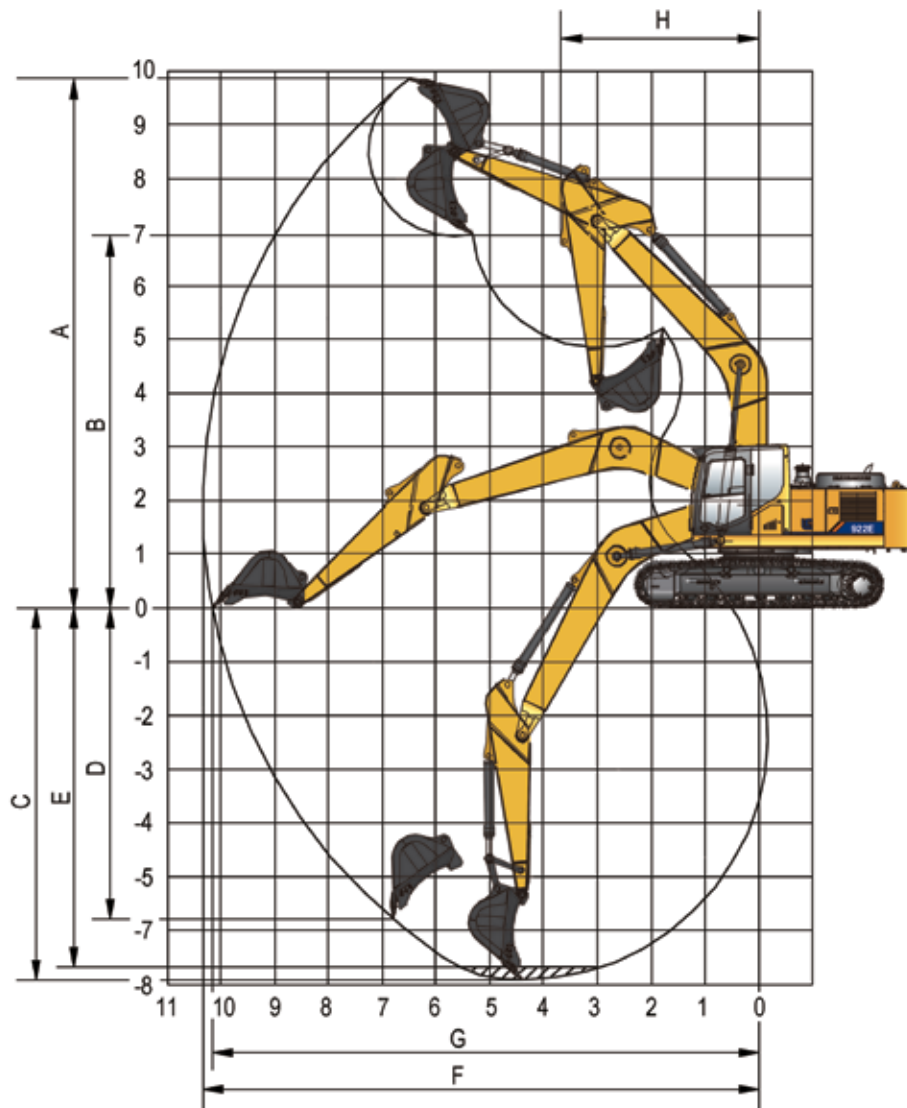

SPECIFICATIONS

MACHINE WEIGHTS AND GROUND PRESSURE

922E

Shoe width (mm)	Operating weight (kg)	Ground pressure(kPa)	Overall width (mm)
5.7m boom, 2.9m arm, 1.0 m ³ bucket, 4000 kg Counterweight			
600	22800	46.9	2990

BUCKET SELECTION GUIDE

					922E	
					5.7m Boom	
Bucket type	Capacity m ³	Cutting width mm	Weight kg	Teeth pcs	600mm shoe, 4000kg Counterweight	
					2.9m arm	2.7m arm
General Purpose	0.9	1083	786	5	B	B
	0.95	1268	769	5	B	B
	1.0	1227	850	5	A	A
	1.0	1280	905	5	C	C
	1.1	1330	852	5	B	B
	1.2	1420	915	5	A	A

A Used with material weights up to 1300 kg/m³
 B Used with material weights up to 1500 kg/m³
 C Used with material weights up to 1800 kg/m³
 D Used with material weights up to 2100 kg/m³



LIFTING CAPACITY (METRIC)

922E Standard Arm

Conditions

A: Reach from swing center
 B: Bucket hook height
 C: Lifting capacity
 Cf: Rating over front
 Cs: Rating over side

Boom length: 5710mm
 Arm length: 2915mm
 Counterweight: 4000kg
 Shoes: 600mm triple grouser
 Unit: ton

B\A(m)	3		4		5		6		7		8		MAX REACH		A (m)
	Cf	Cs	Cf	Cs	Cf	Cs	Cf	Cs	Cf	Cs	Cf	Cs	Cf	Cs	
7m							5.34	5.34					5.05	5.05	6.6
6m							5.42	5.42	5.51	4.65			5.36	4.46	7.2
5m					6.07	6.07	5.78	5.78	5.65	4.61			4.67	3.92	7.8
4m			8.14	8.14	7.01	7.01	6.36	5.65	5.96	4.55	5.67	3.74	5.67	3.74	8.0
3m			10.1	9.68	8.1	7.07	7.03	5.51	6.38	4.46	5.71	3.7	5.51	3.56	8.2
2m			11.88	9.22	9.18	6.82	7.71	5.34	6.82	4.36	5.65	3.64	5.15	3.4	8.4
1m			13.09	8.94	10.06	6.63	8.31	5.21	6.76	4.28	5.61	3.58	5.42	3.48	8.2
0m	8.21	8.21	13.67	8.81	10.64	6.5	8.34	5.13	6.69	4.21	5.57	3.54	5.38	3.45	8.2
-1m	11.67	11.67	13.77	8.76	10.89	6.42	8.27	5.07	6.65	4.17			5.75	3.66	7.8
-2m	15.75	13.82	13.51	8.77	10.82	6.42	8.27	5.05	6.65	4.17			6.17	3.91	7.4
-3m	16.4	13.97	12.84	8.85	10.39	6.46	8.31	5.09					5.15	4.38	7.0
-4m	14.67	14.18	11.63	8.98	9.42	6.57							7.9	5.42	5.8

922E Short Arm

Conditions

A: Reach from swing center
 B: Bucket hook height
 C: Lifting capacity
 Cf: Rating over front
 Cs: Rating over side

Boom length: 5710mm
 Arm length: 2700mm
 Counterweight: 4000kg
 Shoes: 600mm triple grouser
 Unit: ton

B\A(m)	3		4		5		6		7		8		MAX REACH		A (m)
	Cf	Cs	Cf	Cs	Cf	Cs	Cf	Cs	Cf	Cs	Cf	Cs	Cf	Cs	
7m							5.61	5.61					5.11	5.11	6.4
6m					5.69	5.69	5.65	5.65	5.63	4.61			5.63	4.61	7.0
5m					6.34	6.34	6.01	5.76	5.86	4.59			4.92	4.05	7.6
4m			8.61	8.61	7.3	7.3	6.57	5.63	6.15	4.53	4.42	3.72	4.42	3.72	8.0
3m			10.6	9.63	8.4	7.05	7.23	5.5	6.55	4.44	5.71	3.69	4.55	3.55	8.2
2m			12.32	9.22	9.46	6.82	7.9	5.36	6.86	4.36	5.65	3.64	5.46	3.51	8.2
1m			13.4	8.98	10.28	6.65	8.46	5.23	6.76	4.28	5.61	3.59	5.4	3.48	8.2
0m			13.85	8.89	10.8	6.53	8.36	5.15	6.71	4.23	5.57	3.56	5.57	3.56	8.0
-1m	11.72	11.72	13.85	8.85	10.97	6.48	8.31	5.11	6.67	4.19			5.96	3.79	7.6
-2m	16.37	14.02	13.47	8.89	10.85	6.48	8.31	5.11	6.69	4.21			6.44	4.07	7.2
-3m	16.09	14.17	12.71	8.97	10.31	6.53	8.36	5.15					7.32	4.59	6.6
-4m	14.19	14.19	11.32	9.1	9.15	6.65							7.94	5.75	5.6

STANDARD EQUIPMENT

ENGINE SYSTEM

- Cummins diesel engine, turbocharged, 6 Cylinder, common rail
- Auto-idle speed control
- Air filter with pre-cleaner
- Engine oil filter
- Pre-filter with water separator
- Radiator, oil cooler and intercooler
- IPC (Intelligent Power Control) System
- Engine overheat prevention system

HYDRAULIC SYSTEM

- Power boost
- Boom and arm regeneration circuits
- Pilot oil filter
- Load holding valve
- Pilot control shut-off lever
- Swing with anti-reverse function

OPERATOR STATION

- Pressurized and sealed cab with all around visibility, large roof window with sliding sun visor, front window wiper, removable lower window

- 6-working mode selection system: Power Mode, Economy Mode, Fine Mode, Lifting Mode, Breaker Mode, Attachment Mode
- Skylight rooftop
- Air conditioner, heater, defroster
- AM/FM Radio with MP3 audio jack
- Color LCD monitor with alarms, filter fluid change, fuel rate, water temperature, work mode, fault code, working hour, etc
- Glass-breaking hammer
- Cup holder
- Floor mat
- Storage box
- Front glass lower guard

UPPER STRUCTURE

- Rear view mirror (right & left side)
- Dual batteries
- One key for all locks
- Fuel gauge
- Hydraulic oil level gauge
- Storage box

- Swing parking brake
- Boom working lights
- Lights integrated into storage box
- Roll-Over Protective System (ROPS)

UNDERCARRIAGE

- 600 mm triple grouser track-shoes
- 2 piece track-guards (each-side)
- Towing eye on base frame

WORK EQUIPMENT

- 5.7 m boom and 2.9m arm
- 1.0 m³ (SAE, heaped) bucket

OPTIONAL EQUIPMENT

ENGINE SYSTEM

- Electrical fuel refilling pump

HYDRAULIC SYSTEM

- Security valves (2 on boom and 1 on arm)
- Control pattern change valve
- Auxiliary Hydraulic options
Bi directional piping
Hi pressure quick coupler piping
Rotation piping

UPPERSTRUCTURE

- Crash-proof beam

OPERATOR STATION

- Power outlet 24 V to 12 V converter
- 4 LED working lights
- Rotating beacon
- Rear view camera
- Air suspension seat
- Control joysticks with 2 switch (1 is proportional)
- Falling-Object Protective System (FOPS)
- Safety guard for front window
- Travel alarm

UNDERCARRIAGE

- 3 piece track-guards (each-side)

OPTIONS TO ENHANCE YOUR PRODUCTIVITY



LED LIGHTS



FUEL FILL PUMP



ATTACHMENT PIPING



FOPS & ROCK GUARD



REAR VIEW CAMERA



AUTOMATIC GREASING



Guangxi LiuGong Machinery Co., Ltd.
No. 1 Liutai Road, Liuzhou, Guangxi 545007, PR China
T: +86 772 388 6124 E: overseas@liugong.com
www.liugong.com

Like and follow us:



LG-PB-922E-28-01042020-ENG

The LiuGong series of logos herein, including but not limited to word marks, device marks, letter of alphabet marks and combination marks, as the registered trademarks of Guangxi LiuGong Group Co., Ltd. are used by Guangxi LiuGong Machinery Co., Ltd. with legal permission, and shall not be used without permission. Specifications and designs are subject to change without notice. Illustrations and pictures may include optional equipment and may not include all standard equipment. Equipment and options varies by regional availability.